

Features of the MK series

- Very sensitive response characteristic
- Function is not impaired by high back pressure
- Automatic air-venting (trap can be used for thermal air-venting in steam systems)
- Installation in any position (horizontal and vertical lines)
- High hot-water capacities even with low differential pressures
- With tandem seat (double sealing) for low condensate flowrates
- Built-in non-return valve (only MK 45)
- Stainless steel internals (corrugated membrane of Hastelloy)
- Design "U" with undercooling capsule: utilization of a certain amount of sensible heat by banking-up of condensate, decreasing the amount of flash steam
- Optional extra: Integrated condensate monitoring for MK 45 (temperature or steam loss)

Application

Type	
MK 45-1 MK 35/31 ¹⁾	With tandem seat (double sealing) For low condensate flowrates, steam-tracing, steam-line drainage, air-venting
MK 45-2 MK 35/32 ¹⁾	With single seat For medium condensate flowrates, steam-tracing, drainage of heat exchangers, air-venting
MK 25/2 ¹⁾ MK 25/2 S ¹⁾ MK 35/2 S ¹⁾ MK 35/2 S3 ¹⁾	With single seat For large condensate flowrates, drainage of heat exchangers
MK 36/51 ¹⁾ MK 36/52 ¹⁾	With tandem seat (double sealing) – with flat gasket For small/large condensate flowrates, steam tracing, steam-line drainage, venting and vacuum-breaking. Also suitable for food, biological and pharmaceutical applications.
MK 45 A-1 MK 45 A-2	For small and large condensate flowrates; steam-tracing, steam-line drainage, air-venting

¹⁾ Can also be used for vacuum breaking (aerating).

Air Venting

Steam Trap for Thermostatic Air-Venting with Membrane Regulator

The thermostatic steam traps with membrane regulators of the MK series can also be used for air-venting.

Application

Thermostatic steam trap for automatic air-venting and discharge of non-condensable gases and steam/air mixtures from steam lines and heat exchangers.

A special type of membrane regulator capsule might be required.

Pressure/Temperature Ratings

Type	PN / Class	Δ PMX [bar]	Material		Max. Pressure/Temp. Rating ¹⁾			
			EN	ASTM	PMA [bar]	TMA [°C]	p/T [bar/°C]	
MK 35/31, MK 35/32	PN 25	21	1.0460	A105	25.0	400	18.6 / 225	14.4 / 400
MK 45-1, MK 45-2	PN 40	32	1.0460	A105	40.0	450	27.6 / 300	13.1 / 450
MK 45-1, MK 45-2	Class 300	32	1.0460	A105	51.1	425	39.8 / 300	28.8 / 425
MK 35/2 S, DN 25 MK 35/2 S3, DN 25	PN 40	32	1.0460	A105	40.0	450	27.6 / 300	13.1 / 450
MK 25/2, MK 25/2 S, DN 40, 50	PN 40	32	1.0460/ 1.0619	A105/ A216-WCB	40.0	450	27.6 / 300	13.1 / 450
MK 36/51, MK 36/52	–	32	1.4301 ²⁾	A479-F304	49.0	400	32.0 / 250	28.0 / 400
MK 45 A-1, MK 45 A-2	PN 40	32	1.4404	A182-F316L	40.0	400	27.6 / 300	25.7 / 400 ³⁾
MK 45 A-1, MK 45 A-2	Class 300	32	1.4404	A182-F316L	41.4	400	26.1 / 300	24.3 / 400 ³⁾

¹⁾ Limits for body/cover. Functional requirements may restrict the use to below the limits quoted.

For full details on limiting conditions depending on end connection and type of regulator see data sheet.

²⁾ EN material comparable to ASTM material.

³⁾ If the operating temperatures exceed 300 °C intercrystalline corrosion may occur. Do not subject the equipment to operating temperatures higher than 300 °C unless intercrystalline corrosion can be ruled out.

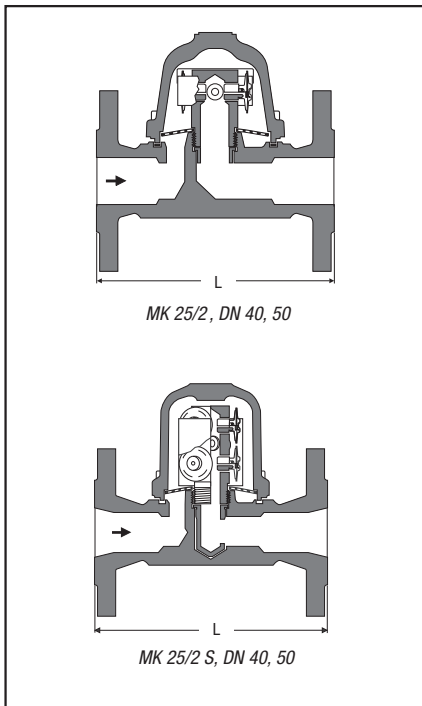

Available End Connections and Overall Length

Type	Connection	Overall length (L) in mm						
		DN 8 1/4"	DN 10 3/8"	DN 15 1/2"	DN 20 3/4"	DN 25 1"	DN 40 1 1/2"	DN 50 2"
MK 45-1	Flanged EN PN 40	–	–	150	150	160	–	–
MK 45-2	Flanged ASME 150 ¹⁾	–	–	150	150	160	–	–
MK 45 A-1	Flanged ASME 300 ¹⁾	–	–	150	150	160	–	–
MK 45 A-2	Screwed sockets	–	–	95	95	95	–	–
MK 35/2 S3 only DN 25	Socket-weld (SW)	–	–	95	95	95	–	–
MK 35/2 S only DN 25	Butt-weld (BW) ²⁾	–	–	200	200	200	–	–
MK 35/31	Screwed sockets	–	70	70	–	–	–	–
MK 35/32	Socket-weld (SW)	–	–	95	–	–	–	–
MK 25/2 DN 40 – 50	Flanged EN PN 40	–	–	–	–	–	230	230
MK 25/2 S DN 40 – 50	Flanged ASME 150	–	–	–	–	–	230	230
	Flanged ASME 300	–	–	–	–	–	230	230
	Screwed sockets	–	–	–	–	–	130	230
	Socket-weld (SW)	–	–	–	–	–	130	230
MK 36/51	Screwed sockets	65	65	65	65	–	–	–
MK 36/52	Union butt-weld nipples ³⁾	–	–	150	–	–	–	–
	Hinged clamp	–	65	65	65	65	–	–

¹⁾ MK 45 with ASME flanges: overall length 172 mm available on request.

²⁾ Only MK 45

³⁾ Made of carbon steel or stainless steel

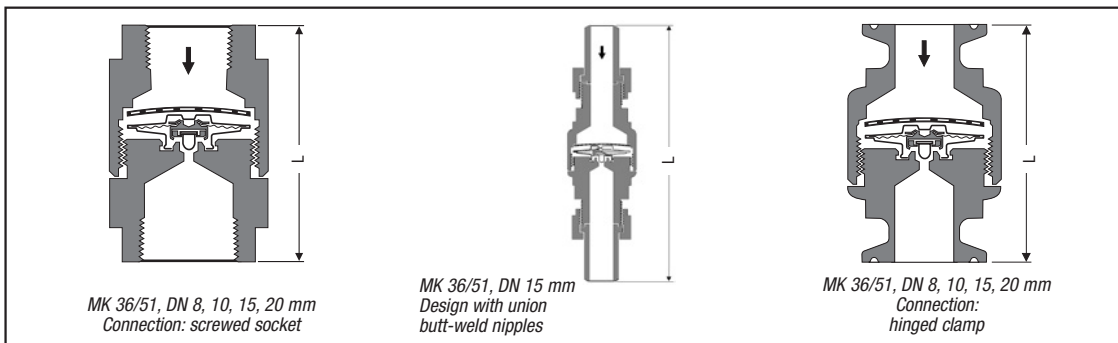

Capacity Charts

The charts show the maximum hot condensate capacities.

MK 45-1/MK 45A-1 (Curve 4) **MK 35/31** (Curve 1)
MK 45-2/MK 45A-2 (Curve 5) **MK 35/32** (Curve 2)
MK 36/51 (Curve 3) **MK 36/52** (Curve 2)

MK 25/2 S, DN 40, 50 (Curve 1) **MK 35/2 S3, DN 25** (Curve 3)
MK 25/2, DN 40, 50 (Curve 2) **MK 35/2S, DN 25** (Curve 4)

